



Lotus FCS518

Surface mounted luminaire suitable for use with
2XPLS9/11/18W compact fluorescent lamps

Features

- Aesthetically designed 3D profile. high grade engineering plastic housing.
- Ventilation slits to provide better thermal performance. and add to the interior ambiance.
- Imported pre anodised optically designed mirrors for efficient & uniform lighting effect
- Mirror assembly and lamellae are integrated with the housing. and is click fixed with the gear tray with 4 cam springs.

Application

- Reception and public service areas
- High end offices
- Conference rooms
- Recreational areas
- Departmental stores
- Shops, boutiques
- Staircase landings

Related products



FCS518m

Dimensional drawing

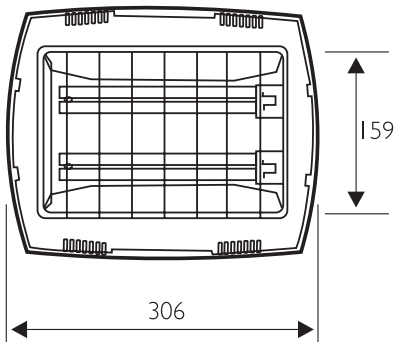
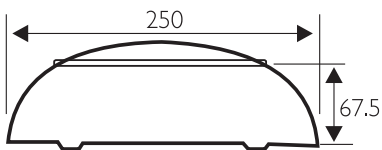

FCS518

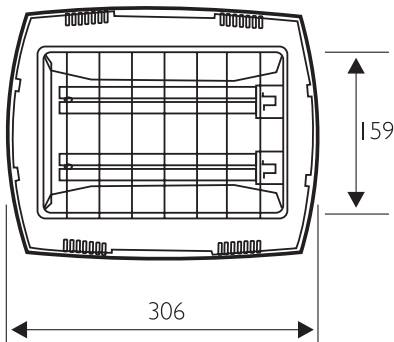
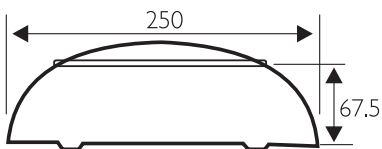

FCS518

General information

Order code	Product family code	Number of lamps	Lamp family code	Lamp power	Gear	Compensation circuit
919015044817	FCS518	2	PL-L	18 W	HF	-
919215000146	FCS518	2	PL-S/2P	11 W	-	I
919215000147	FCS518	2	PL-S/2P	9 W	-	I
919615810136	FCS518	2	PL-L	18 W	HF	-
919615810179	FCS518	1	PL-S/4P	9 W	HFE	-

Electrical

Order code	Product family code	Supply voltage
919215000146	FCS518	240 V

Order code	Product family code	Supply voltage
919215000147	FCS518	240 V



© 2011 Koninklijke Philips Electronics N.V.
All rights reserved.

Specifications are subject to change without notice. Trademarks are the property of Koninklijke Philips Electronics N.V. or their respective owners.

www.philips.com/lighting

2011, December 20
data subject to change